

SUNUs

轉盤軸承 Slewing bearing



SUNUs TECH CO.,LTD

TEL:+886-4-2528-8879

FAX:+886-4-2528-8829

<http://www.sunusdrive.com>

E-mail:sun-us@umail.hinet.net



SUNUS

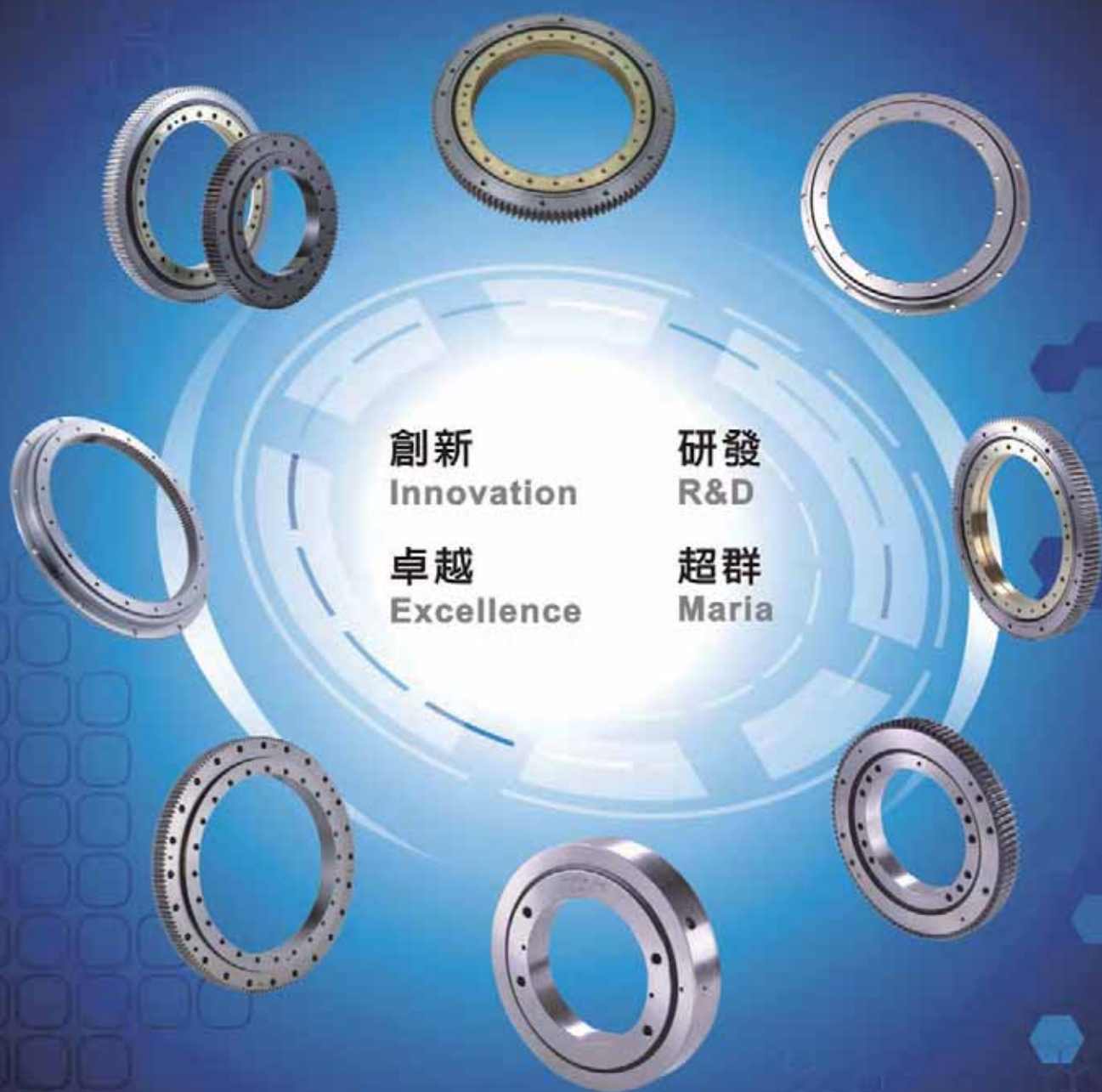

創新
Innovation

卓越
Excellence

研發
R&D

超群
Maria

* 所有技術資料及用詞，均在出版前通過校對，但因產品不斷的研究、發展，我們保留最終修改權。
關於本型錄中之資料若有出入，以本公司實際提供之圖面及資料為準。

* 未經SUNUS許可，不得以任何方式複印。



SUNUS 堅持以不斷的創新、研發，追求產品的卓越超群，並遵循ISO9001國際品質管理系統的要求，以提供符合客戶滿意的產品和服務。

本公司具有優質卓越的設計能力，熟練的組裝技術與五十年以上的零組件加工經驗和誠信的經營理念，秉持品質保證、顧客滿意的精神，提供客戶高品質的轉盤軸承。

SUNUS insist on innovation and development continuous to pursuit the best quality and follow the principle of ISO9001 and provide the satisfying product and service . Our company own the excellent designing ability , sophisticated assembly-technique and process experience more than 50 years , based on quality warranty , spirit of satisfying service , further provide the customer high quality slewing bearing.

轉盤軸承產品特點：

轉盤軸承能夠同時承受較大的軸、徑向負荷與傾覆力矩，軸承內圈與外圈帶有安裝孔、潤滑油孔、齒輪，可以滿足各種條件的需求。轉盤軸承內圈與外圈滾動軌道熱處理後經研磨加工，降低摩擦力；耐磨耗使用壽命長；高載荷能力。齒輪齒面熱處理後經研磨加工，齒面光滑、齒形精準。

SUNUS 製造除標準外亦可客製化轉盤軸承，外徑最大可達2500mm。

Characteristics of slewing bearing:

Slewing bearing can afford both heavy axial and radial loads as well as upsetting moment simultaneously. The inner and outer rings of the bearing have mounting holes, lubricating oil holes and gears, meeting the needs of various conditions. The inner and outer rings in the raceway of the slewing bearing are ground after induction hardened. Its characteristics include but do not limited to wear-resistance, long service life and high load capacity. The tooth surface of the gear is ground first and treated with heat treatment afterwards, resulting in the smoothness of the tooth surface and the precision of the tooth shape.

SUNUS Manufactures both standard-size and custom-made slewing bearings with the condition of bearing diameters could reach 2500mm.

應用：

工具機

CNC龍門銑床
CNC Gantry Milling Machine
CNC落地搪床
CNC Floor Boring Machine
CNC重型臥車、立車
CNC Heavy Duty Lathe
(Horizontal or Vertical Spindle)

自動化設備

半導體機械設備
Semiconductor Machinery and Equipment
光電面板業
Solar Photovoltaic Panel Industry
自動倉儲運輸系統
Automated Storage and Retrieval System

產業機械

風力發電機
Wind Turbines
潛盾機
Tunnel Boring Machines
船隻吊掛設備
Boat Hoists
橋式起重設備
Tower Crane

SUNUS 轉盤軸承 Slewing Bearing

- 交叉滾柱式外齒轉盤軸承【CRE系列】
Cross roller slewing bearing with external gear【CRE series】

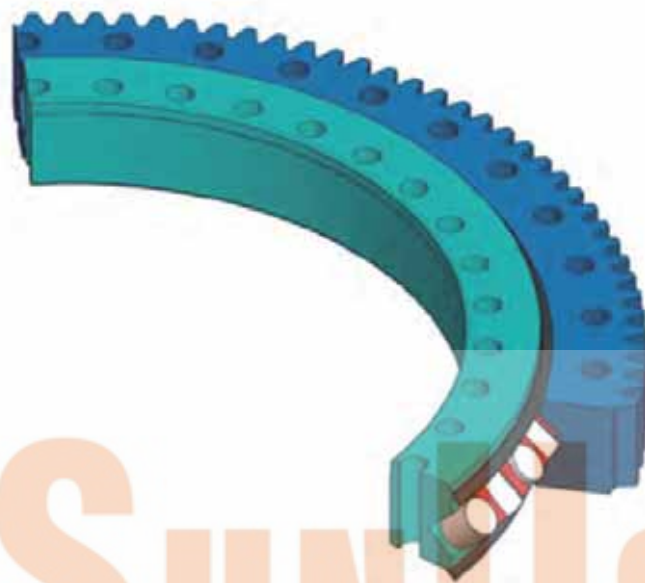

- 交叉滾柱式內齒轉盤軸承【CRI系列】
Cross roller slewing bearing with internal gear【CRI series】

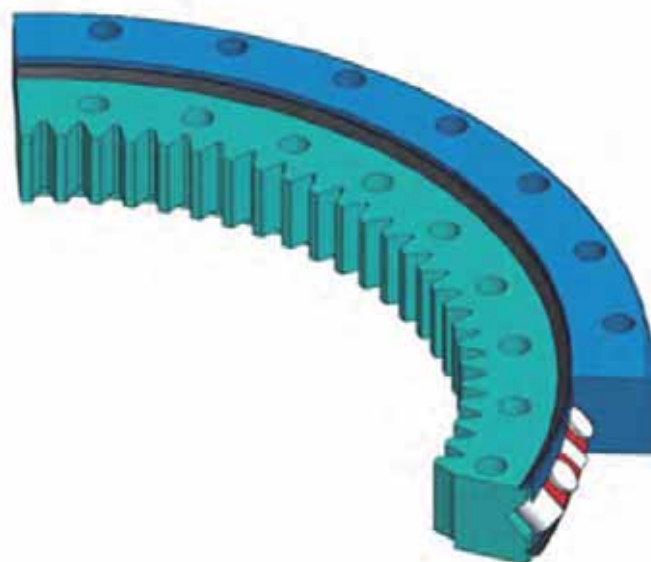

- 滾珠式外齒轉盤軸承【BTE系列】

Ball type slewing bearing with external gear【BTE series】

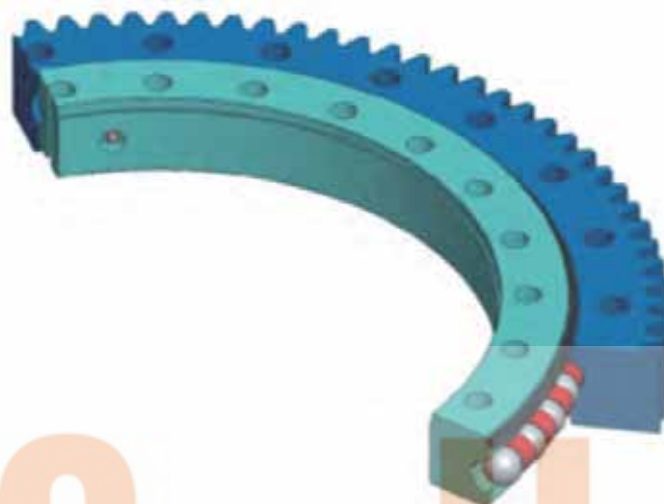

- 滾珠式內齒轉盤軸承【BTI系列】

Ball type slewing bearing with internal gear【BTI series】

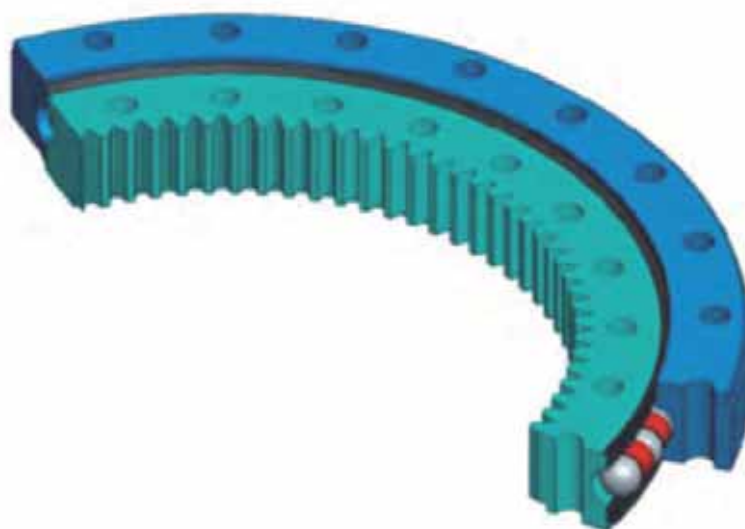

SUNUs 轉盤軸承 Slewing Bearing

結構:

內環(a)，外環(b)，鋼球或滾柱(c)，間隔器(d)，齒輪(e)，
通孔或螺紋孔(f)，密封環(g)，軌道(h)，黃油嘴(i)

Structure:

Inner ring (a), outer ring (b), ball or roller (c), spacer (d), gear (e),
hole or screw hole (f), seal (g), raceway (h), grease nipple (i)

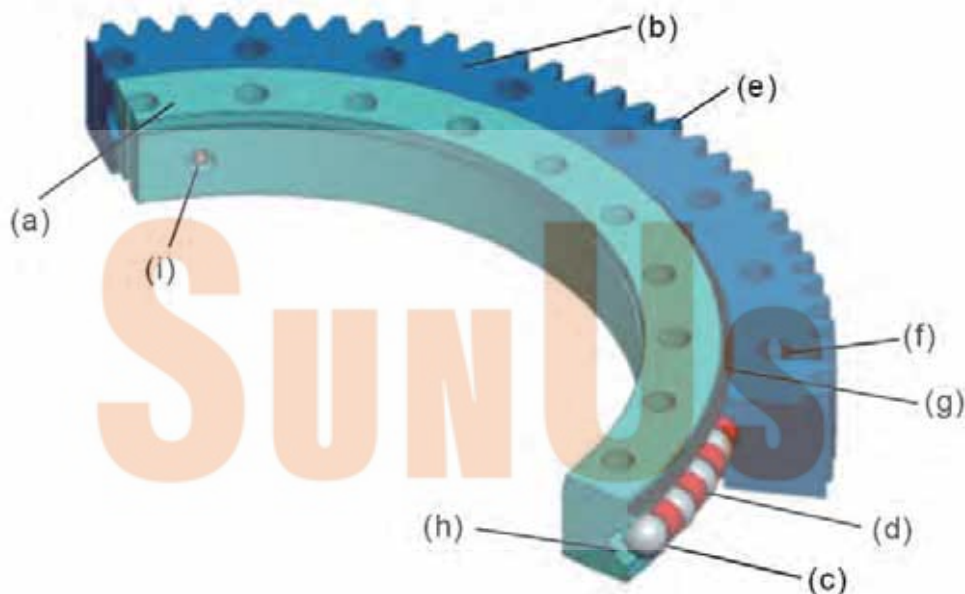

材質:

內、外環: DIN 42CrMo4 (JIS SCM440)，軌道與齒面經高週波熱處理後研磨，

齒輪精度DIN 6級(JIS N6)

鋼球或滾柱: DIN 100Cr6 (JIS SUJ2)

密封環: 丁腈橡膠 (NBR)

Materials:

Inner ring and outer ring: DIN 42CrMo4 (JIS SCM440), raceway and teeth surface are
induction- hardened and ground. Gear accuracy reaches JIS (N6).

Ball or roller: DIN 100Cr6 (JIS SUJ2)

Seal: NBR

徑向偏擺 Radial runout

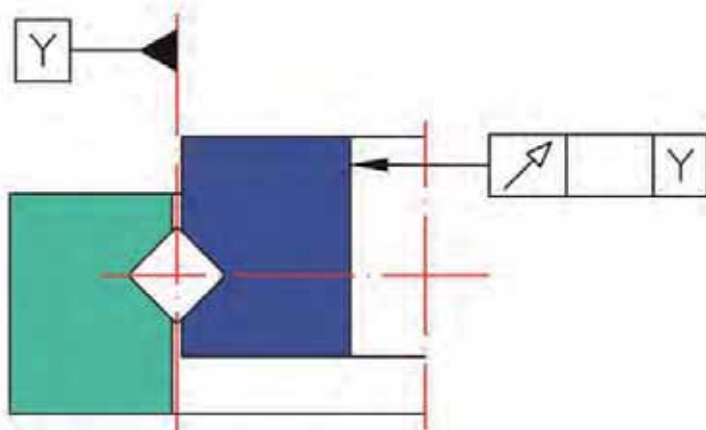

軸向偏擺 Axial runout

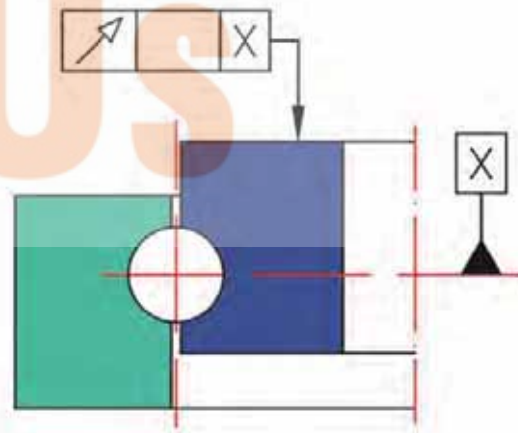
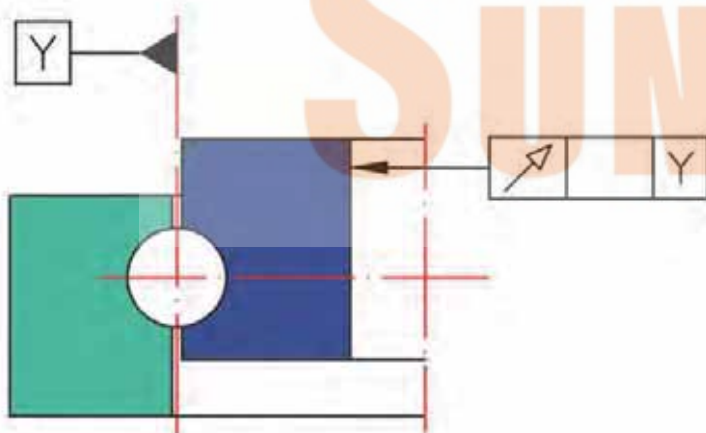
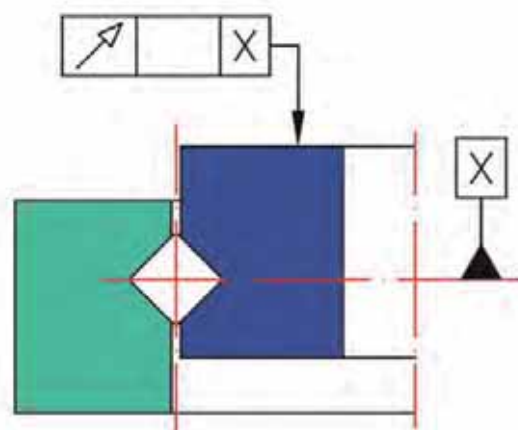

偏擺精度 Accuracy

軌道直徑(mm) Raceway diameter(mm)	徑向偏擺最大值(mm) Maximum radial runout (mm)	軸向偏擺最大值(mm) Maximum axial runout(mm)
0~500	0.1	0.15
501~1000	0.15	0.2
1001~1500	0.18	0.25

選用範列：C R E . 1 4 . 0 6 4 4 .

Example: . . .

型式選擇: Series
CR/BT

齒部位置: Gear position
E: 外齒輪 External gear
I: 內齒輪 Internal gear

滾珠或滾柱直徑: Ball or Roller size
14 16 20 25 30

表面處理: Surface treatment
防銹油 Oil storage protection
磷酸錳處理 Manganese phosphate coating
化學鍍處理 Chemical nickel plating

軸承直徑(軌道直徑):
Bearing size (raceway diameter)
0342 0380 0414 0422 0489 0508
0520 0544 0555 0573 0574 0626
0644 0673 0675 0720 0734 0744
0765 0770 0820 0823 0844 0849
0880 0885 0936 0944 0946 0947

* 如有客製需求，請洽本公司業務部。

CRE 系列 CRE Series

交叉滾柱式外齒轉盤軸承

Cross roller slewing bearing with external gear

SUNUS

CRE.14.0414

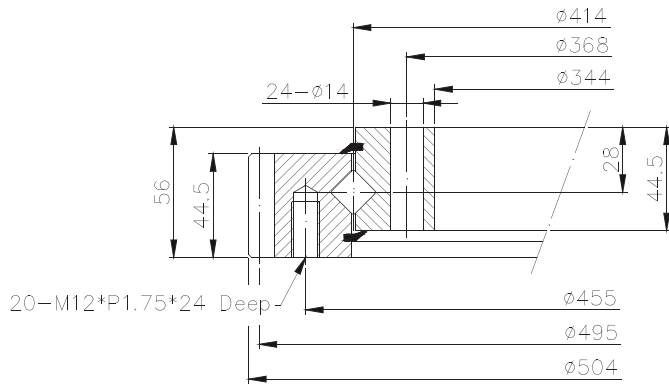

CRE.30.0508

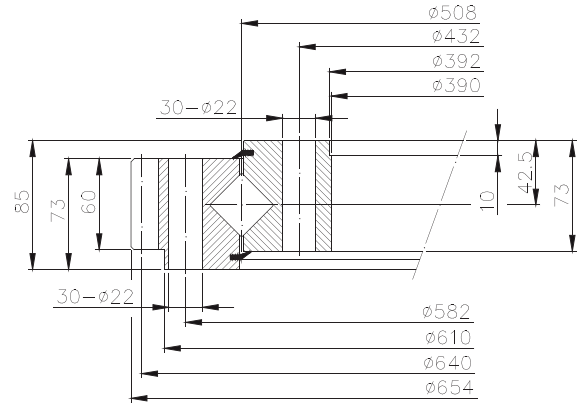

CRE.14.0544

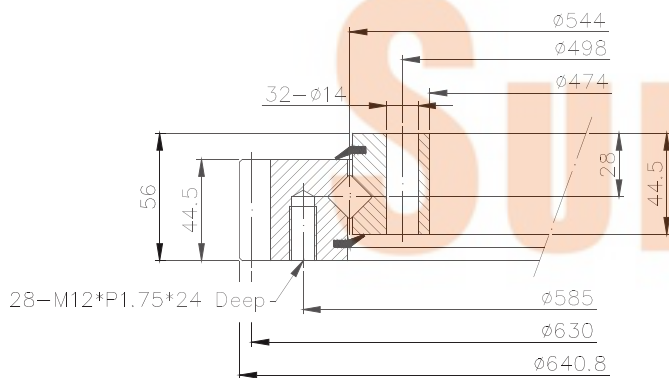

CRE.25.0574

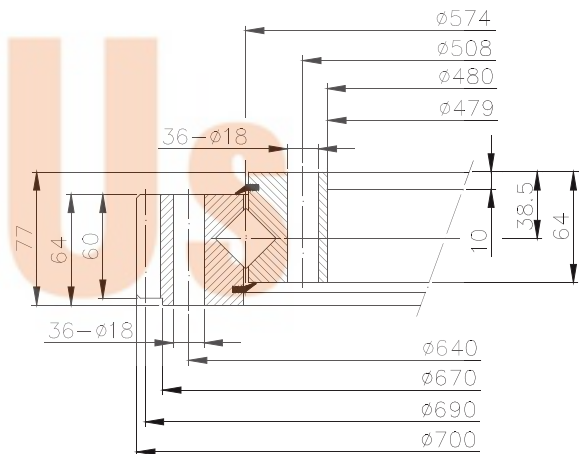

CRE.14.0644

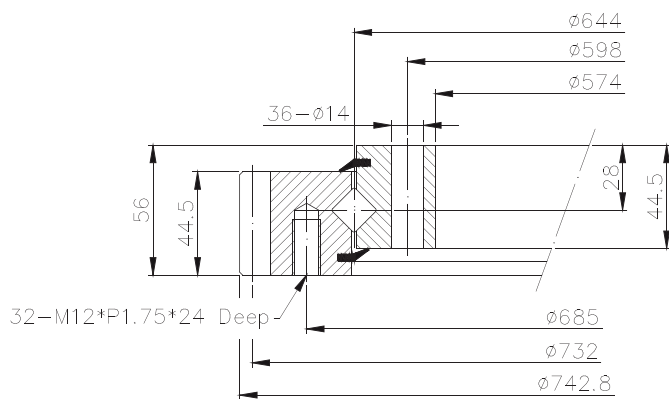

CRE.25.0675

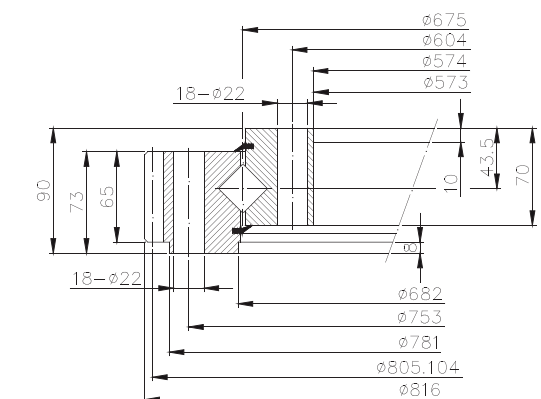

CRE.30.0734

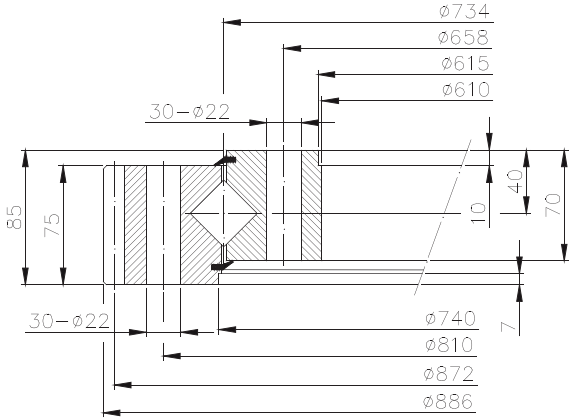

CRE.14.0744

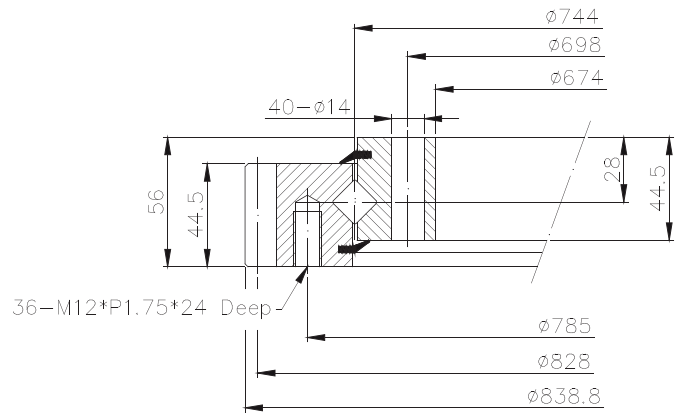

CRE.30.0823

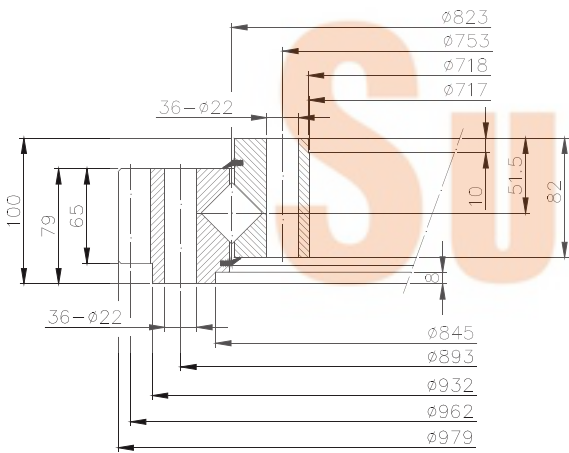

CRE.14.0844

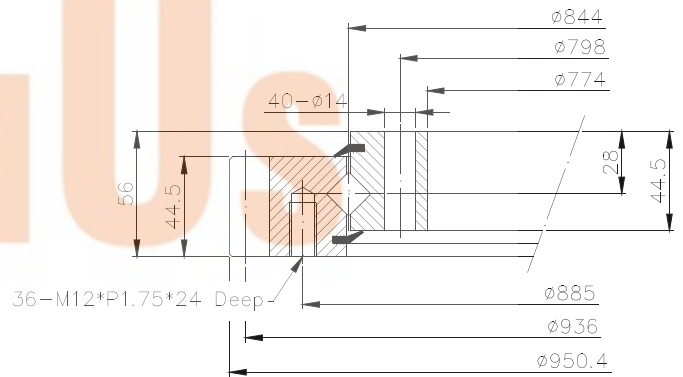

CRE.14.0944

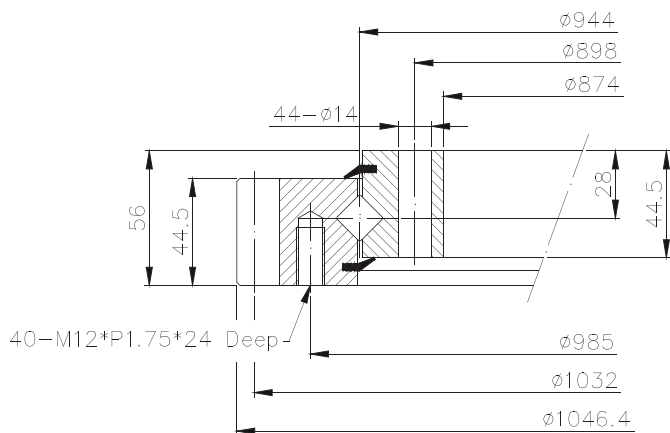

CRI 系列 CRI Series

交叉滾柱式內齒轉盤軸承

Cross roller slewing bearing with internal gear

SUNUS

CRI.16.0380

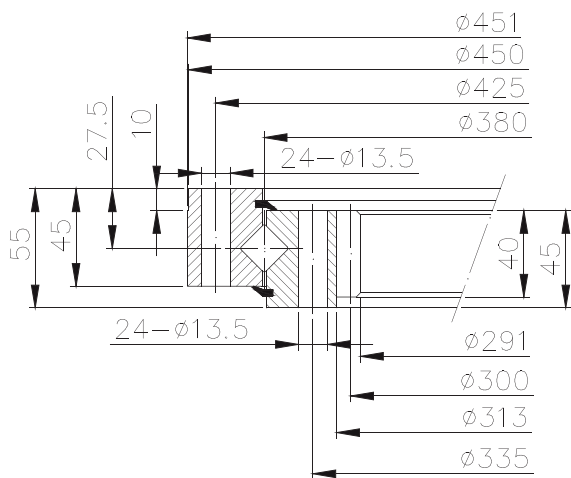

CRI.14.0414

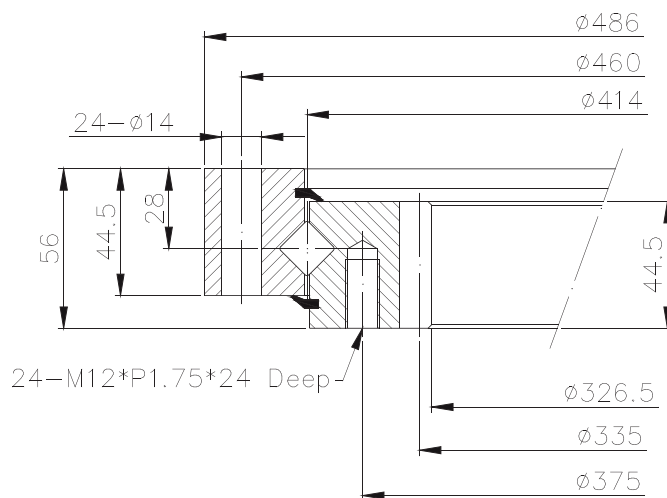

CRI.20.0489

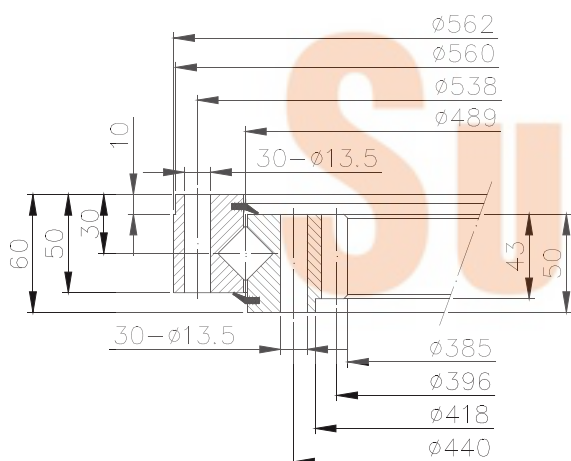

CRI.14.0544

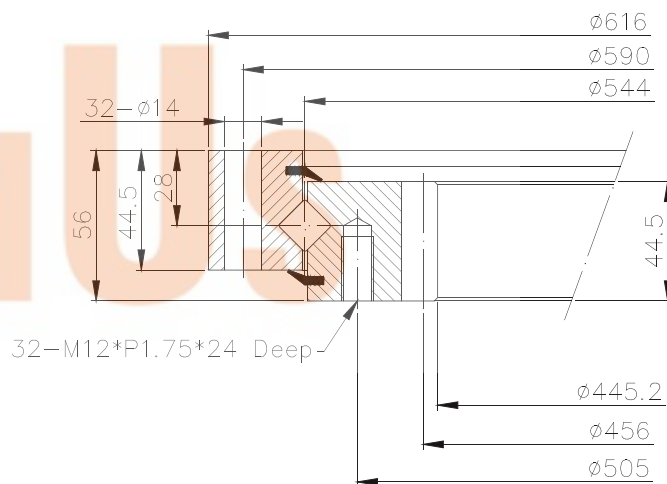

CRI.20.0573

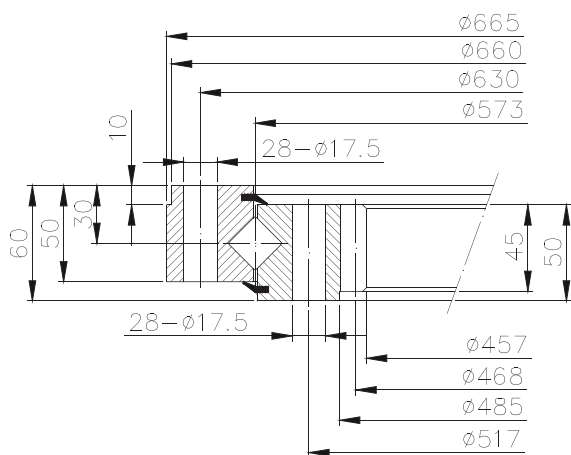

CRI.14.0644

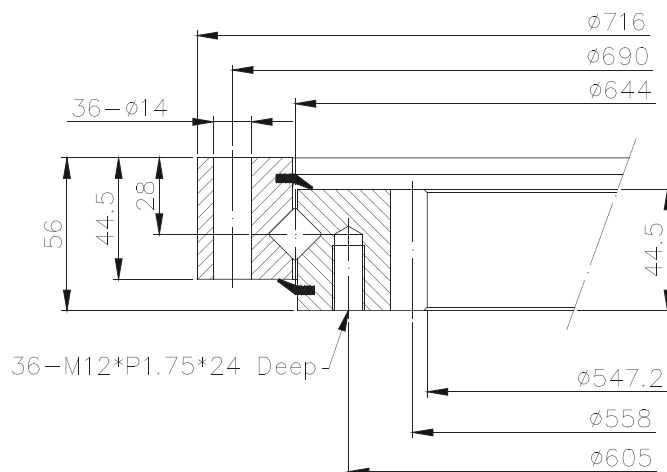

CRI.20.0673

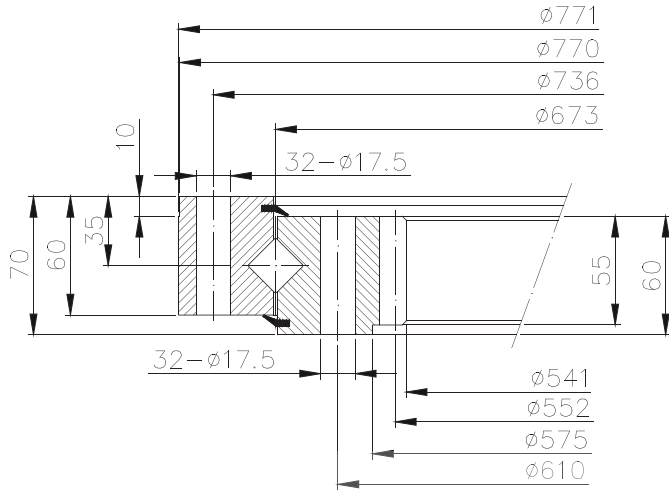

CRI.14.0744

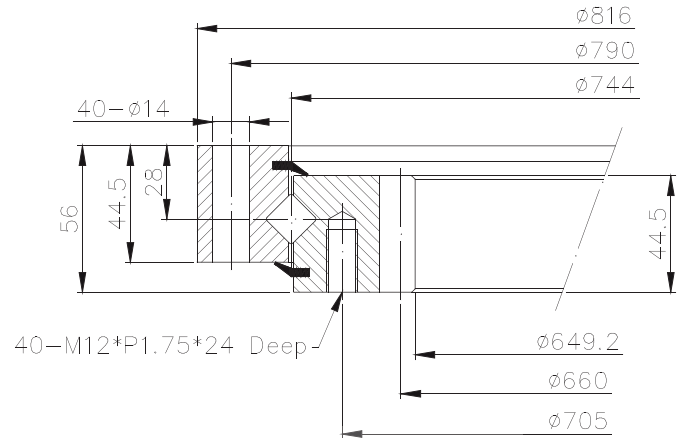

CRI.25.0770

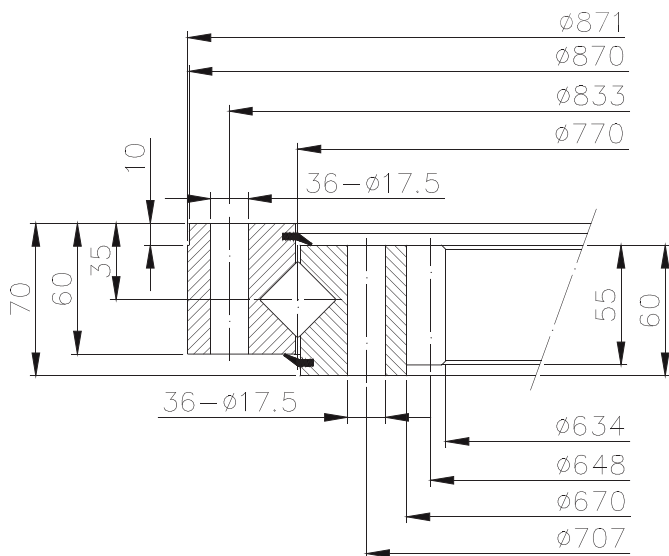

CRI.14.0844

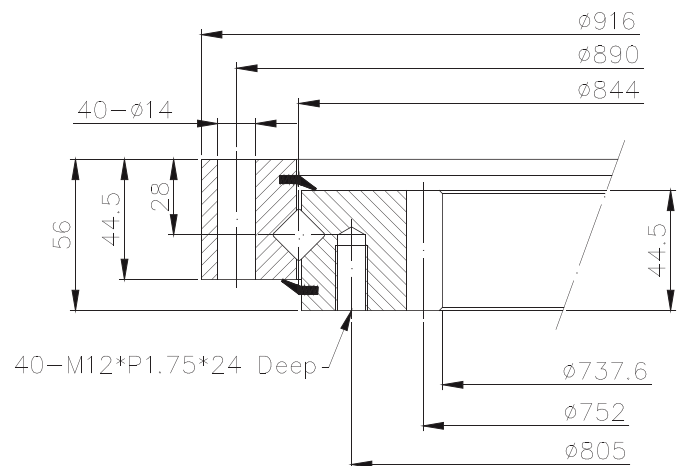

CRI 系列 CRI Series

交叉滾柱式內齒轉盤軸承

Cross roller slewing bearing with internal gear

SUNUS

CRI.25.0849

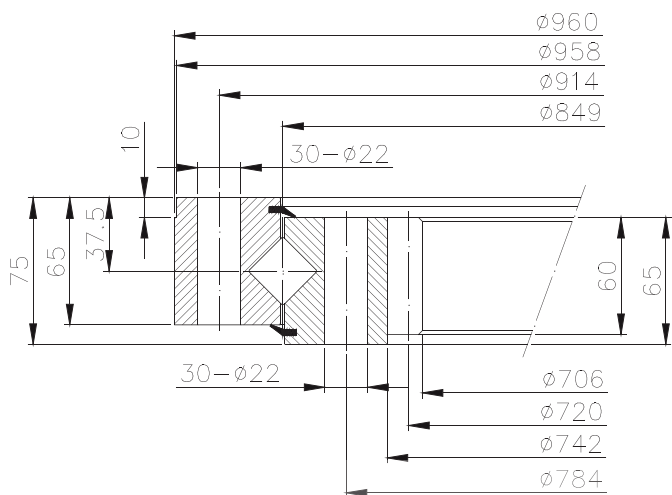

CRI.25.0885

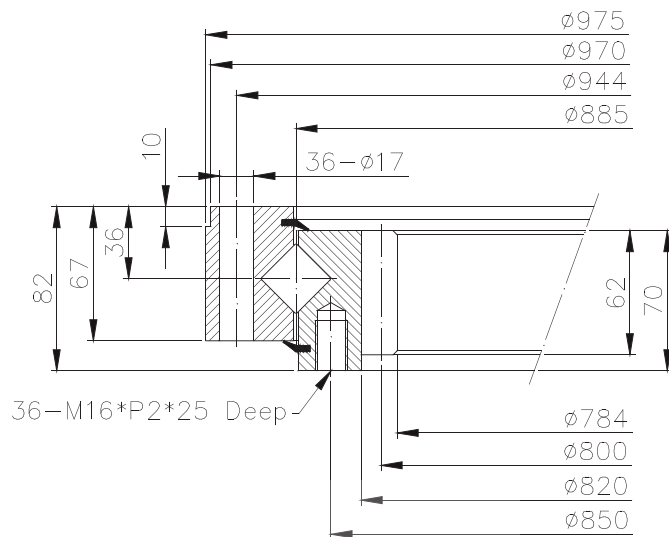

CRI.14.0944

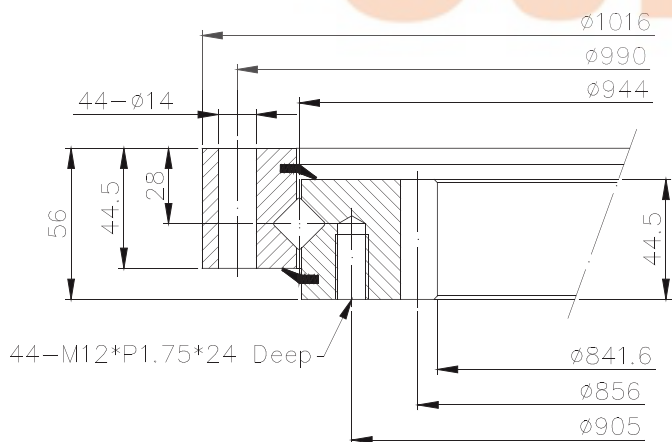

CRI.25.0946

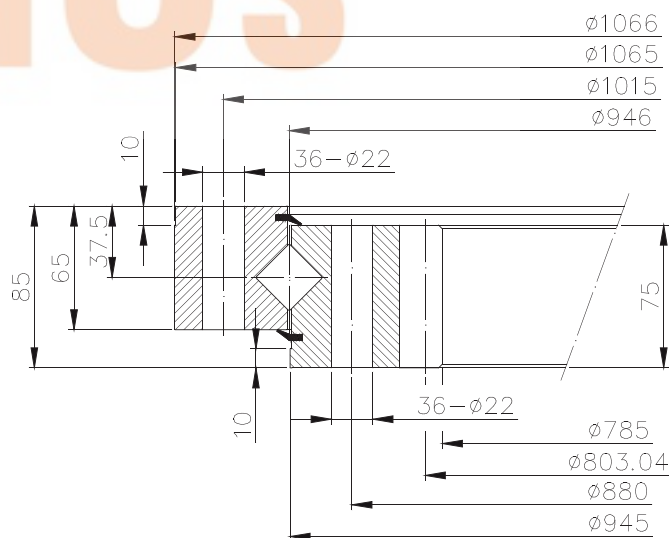

BTE.20.0342

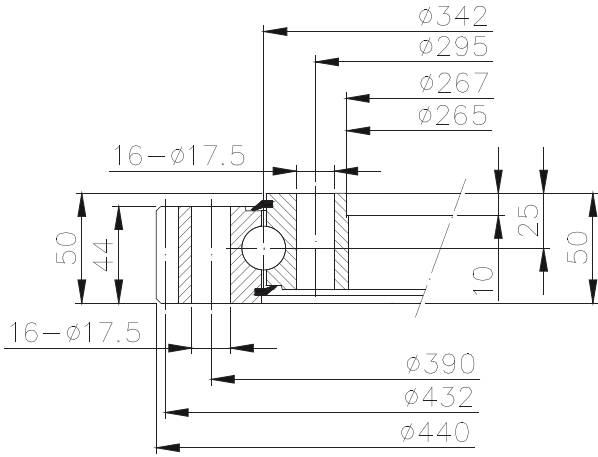

BTE.20.0414

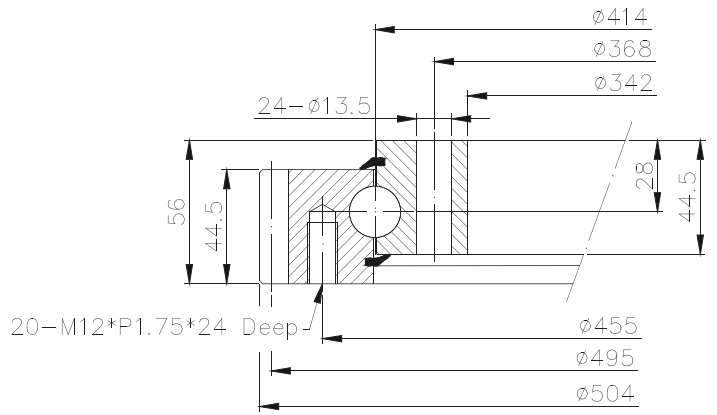

BTE.25.0422

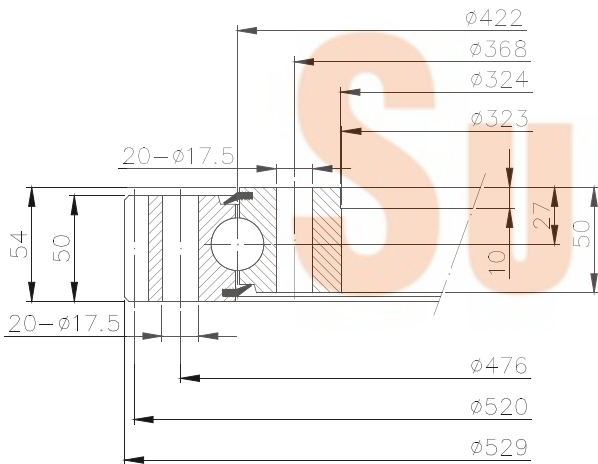

BTE.20.0544

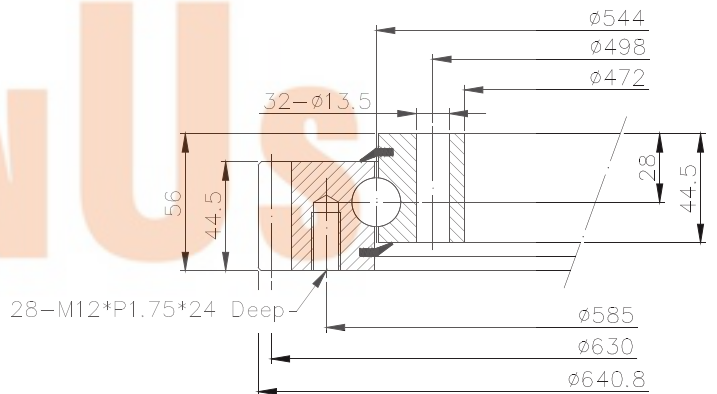

BTE.25.0555

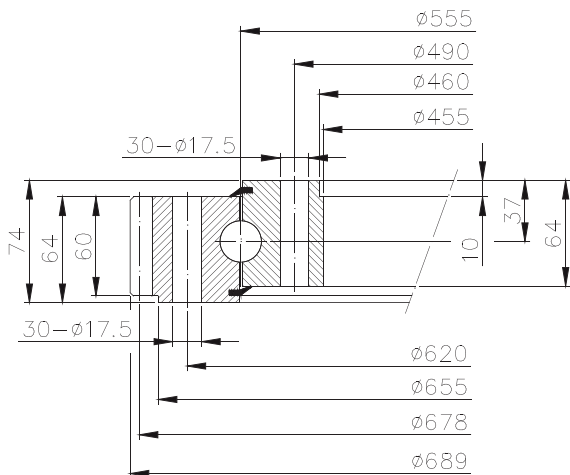

BTE.30.0626

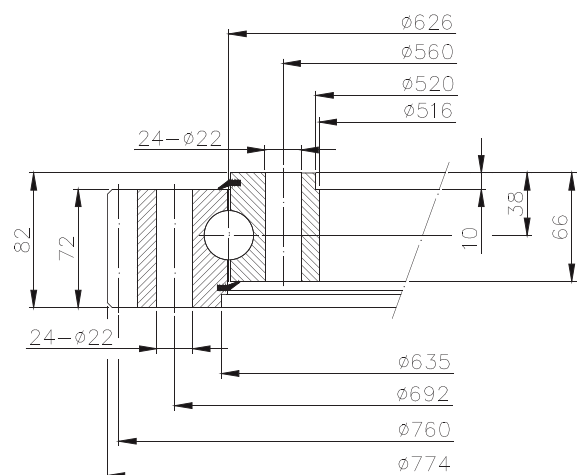

BTE 系列 BTE Series

滾珠式外齒轉盤軸承

Ball type slewing bearing with external gear

SUNUs

BTE.20.0644

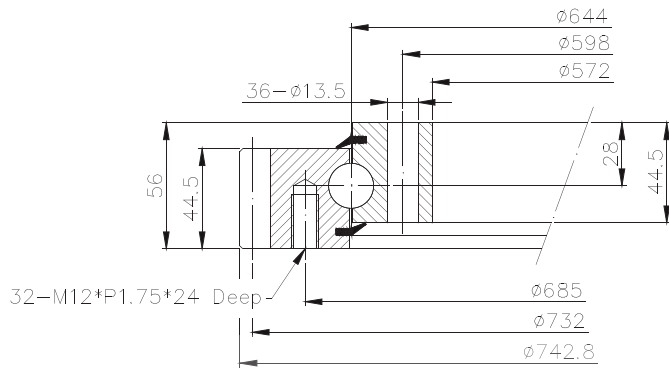

BTE.20.0744

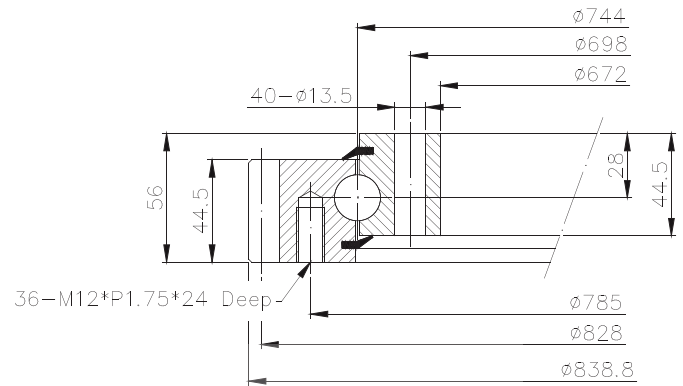

SUNUs

BTE.30.0765

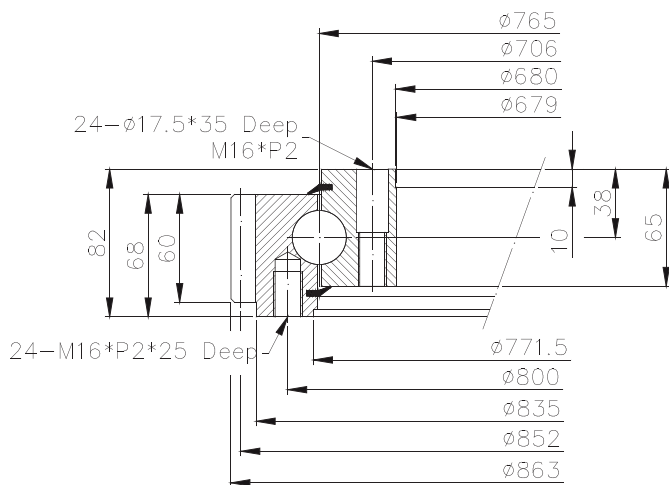

BTE.20.0844

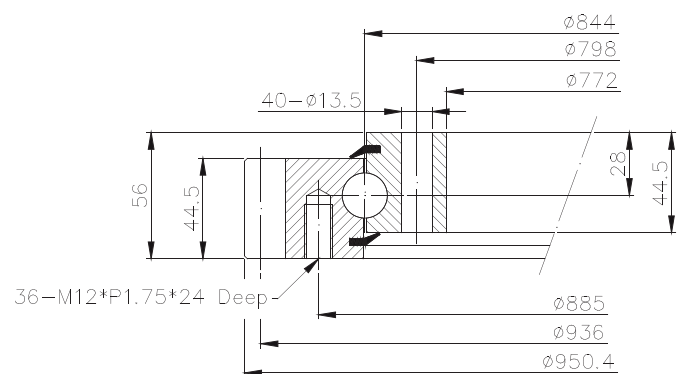

BTE.30.0880

BTE.20.0944

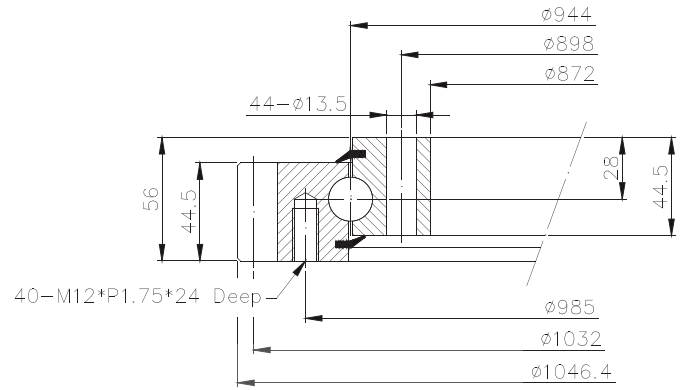
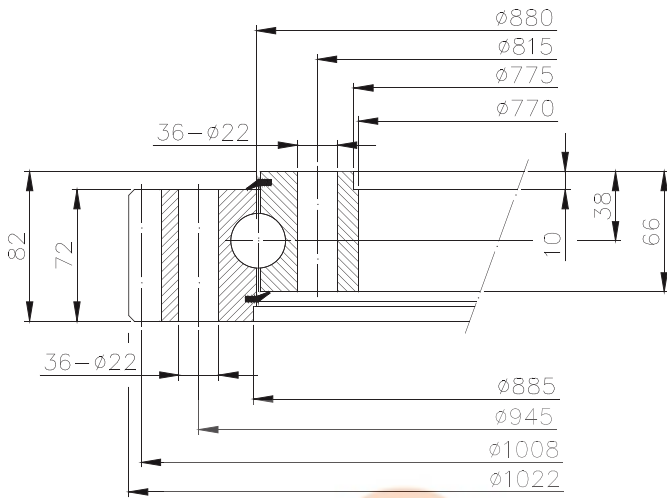

BTE.30.0947

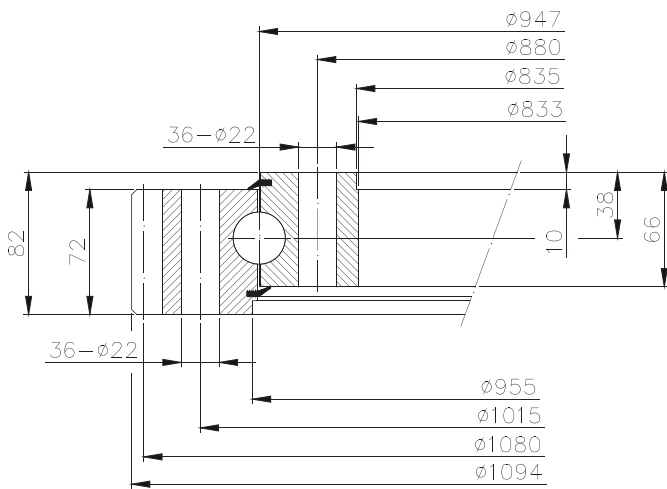

我們提供下列客製化服務

1. 行星式減速機、減速傳動機構、精密傳動元件等設計製造。
2. 承接客戶委託, 設計製造之減速機。
3. 精密研磨級齒輪齒條、蝸桿及蝸輪製造。



SUNUs



SUNUs TECH CO., LTD.
晶傑精機有限公司



台灣總公司

晶傑精機有限公司
台中市豐原區豐勢路一段431號
TEL:+886-4-2528-8879
FAX:+886-4-2528-8829
<http://www.sunusdrive.com>
E-mail:sun-us@umail.hinet.net
Skype:sunustechcoltd

大陸地區

昆山金吉品機器有限公司
江蘇省昆山市玉山鎮城北中路1288號
正泰隆國際裝備採購中心1館1樓1027號
TEL:0512-3669-4767
FAX:0512-3669-4757
E-mail:ksjjpq@163.com

代理商